

STANNAH LIFTS LTD

TECHNICAL BULLETIN**INFORMATION ONLY**

For the Attention of : Service Engineers, Installers, Trade Customers, Testers,
Training Dept, H & S Manager

Date : 13-10-2009

Product : Maxilift MRLi Hydraulic Passenger Lifts

Subject : Introduction of Pawl Device on MRLi models

Pages : 2

Originator : Stannah Lifts Ltd, Anton Mill, Andover, Hants SP10 2NX 01264 339090

Introduction

In addition to the pawl device retrofit campaign (currently underway on MRLi's in the field) we have now introduced the same pawl device on all production MRLi's manufactured after 11th October 2009.

Detail

If unintended descent of the lift occurs, the pawl device offers protection to passengers and engineers by activating the lift's instantaneous safety gear.

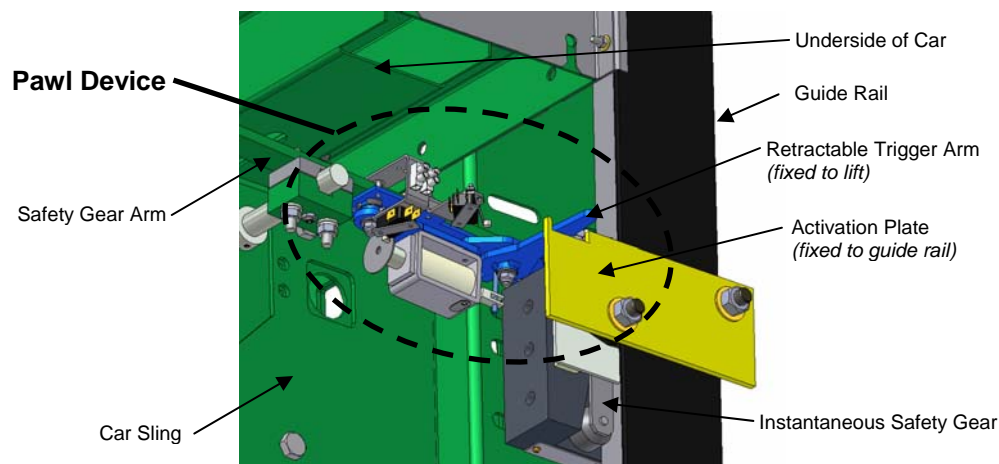

MRLi-P: On models with the control panel located in the pit, the manually operated safety gear tripping device (often referred to as the "kite switch") and the pawl device must both be fitted. The "kite switch" is retained to permit safe movement of the lift within a designated zone in the well via the pit pendant control.

MRLi-A and MRLi-R: The "kite switch" is no longer a requirement on these models where the control panel is outside of the lift well. The pawl device achieves the same level of protection for engineers in the pit. There is no requirement to run this model of lift whilst persons are in the pit.



Note: MRLi's with 2 car entrances are wired slightly differently to single entrance cars. Please ensure that you refer to the correct drawing in the Issue 19 Wiring Manual.

Further Documentation

A Pawl Device Installation Guide has been produced and is available at:

<http://www.stannahtechnical.co.uk/images/System21/install/pawl%20device%20installation%20guide-PRODUCTION%20030809.pdf>

The Installation Guide includes important information including safe working procedures and setting up dimensions, please refer to the document before commencing installation.

Summary

MRLi's manufactured after 11th October 2009

- MRLi-P's will be equipped with: Blain Valve, Kite Switch and Pawl Device
- MRLi-A's and MRLi-R's will be equipped with: Blain Valve and Pawl Device

All Stannah Hydraulic passenger lifts are provided with an interlocked pit prop in addition to the above MRLi specific items.

Note: The above web link is for the pawl device on new installations only. Retrofit of the pawl device on existing installations requires additional work, for example: modifications to the control panel. A different Installation Guide has therefore been produced ("Retrofit Version"). This can be found in the Servicing section of the Stannah technical website.